



Description

The IS31AP4991 evaluation board is a fully assembled and tested PCB that uses the IS31AP4991 Class-AB power amplifier to drive an 8Ω or larger speaker in portable audio applications. The evaluation board accepts a single-ended input signal. The evaluation board provides a BTL output capable of delivering 1.2W into an 8Ω speaker at 5V.

Features

- Supply voltage range from 2.7V to 5.5V
- Delivers 1.2W into an 8Ω speaker at 5V supply. (THD+N=10%).
- Ultra-low distortion (0.025%@0.5W, 1kHz)
- Available in MSOP-8 and SOP-8 package

Quick Start

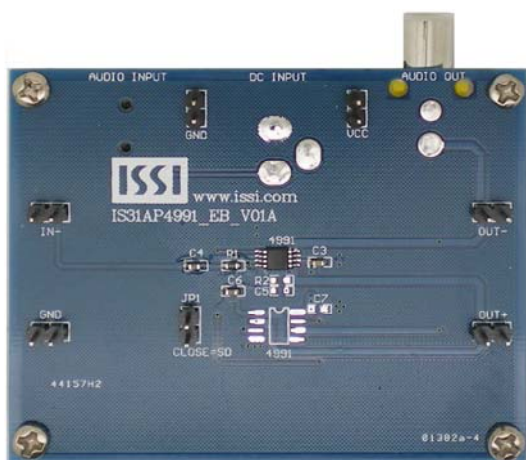

Figure 1. Photo of IS31AP4991 Evaluation Board

Recommended Equipment

- 5.0V, 2A power supply
- Audio source (i.e. MP3 player, Notebook PC) 8Ω Speakers

Absolute Maximum Ratings

- ≤ 5.5V power supply

Caution: Do not exceed the conditions listed above; otherwise the board will be damaged.

Procedure

The IS31AP4991 evaluation board can be used to verify IC operation by following these procedures.

Caution: Do not turn on the power supply until all connections are completed.

1. Connect an 8Ω (or larger) speaker across the OUT-terminal and OUT+ terminal. Or connect speaker to the connector (AUDIO OUT).
2. Connect the ground terminal of the power supply to the GND and the positive terminal to the VCC. Or connect DC power to connector (DC INPUT).
3. Connect the audio source to the IN- terminal; or connect audio source to the connector (AUDIO INPUT).
4. Turn on the power supply.
5. Turn on the audio source.

Ordering Information

Part No.	Temperature Range	IC Package
IS31AP4991-SLS2-EB	-40°C to +85°C (Industrial)	MSOP-8 or SOP-8, Lead-free

Table 1. Ordering Information

For pricing, delivery, and ordering information, please contact ISSI at analog_mkt@issi.com or call +1-408-969-6600

Device Operation

The IS31AP4991 evaluation board features the IS31AP4991 Class-AB power amplifier IC, designed for driving speakers with a load of 8Ω or greater.

Gain Configuration

The IS31AP4991 evaluation board comes with preset gain of 18.3dB and which is controlled by resistors R_I (R₁) and R_F (R₂). Adjust the values of resistors R_I and R_F to obtain the desired gain setting. These resistances can be obtained from Equation (1)

$$Gain = \frac{2 \times R_F}{R_I} \left(\frac{V}{V} \right) \quad (1)$$

High-Pass Filter Configuration

The input capacitor C_I (C₄) and input resistor R_I (R₁) form a high-pass filter with the corner frequency, f_c, determined in Equation (2) and refer to IS31AP4991 data sheet for more detail.

$$f_c = \frac{1}{(2\pi R_I C_I)} \quad (2)$$

Shutdown Mode

Jumper (JP1) controls the shutdown pin of the IS31AP4991 IC. Connect the shunt across pins 1 and 2 of jumper (JP1) to put the board in shutdown mode.

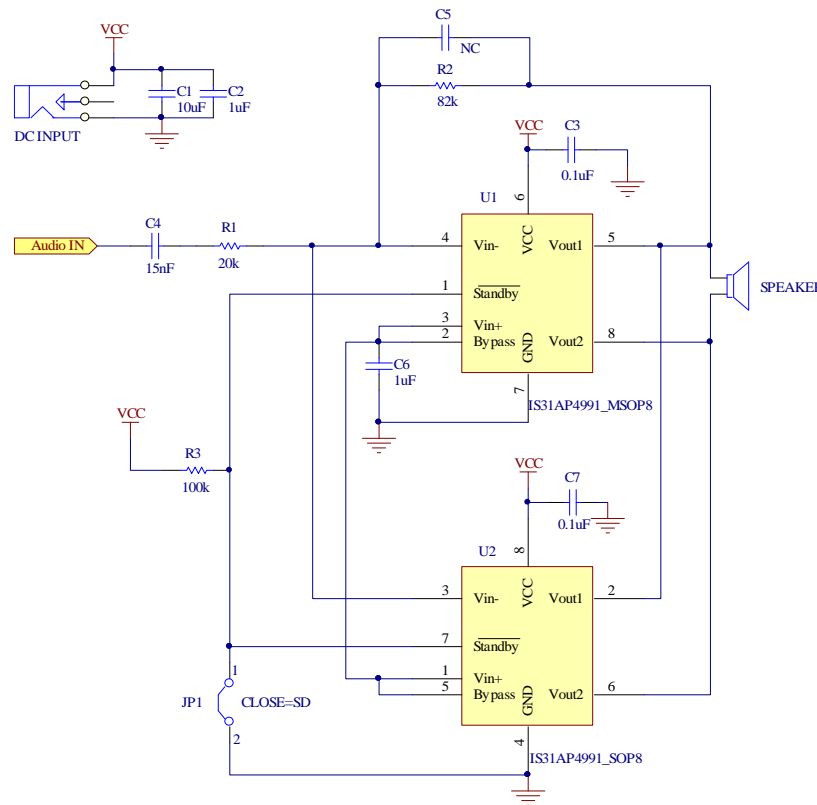

Figure 2. IS31AP4991 Application Circuit

**Bill of Materials**

No.	Name	Description	Symbol	Manufacturer PN
1	Audio Amplifier IC	Class AB	U1, U2	IS31AP4991
2	Resistor	20k Ω	R1	
3	Resistor	82k Ω	R2	
4	Resistor	100k Ω	R3	
5	Capacitor	10 μ F	C1	
5	Capacitor	15nF	C4	
7	Capacitor	1 μ F	C2, C6	
8	Capacitor	0.1 μ F	C3, C7	

Table 2. Please refer to Figure 2 for additional information.

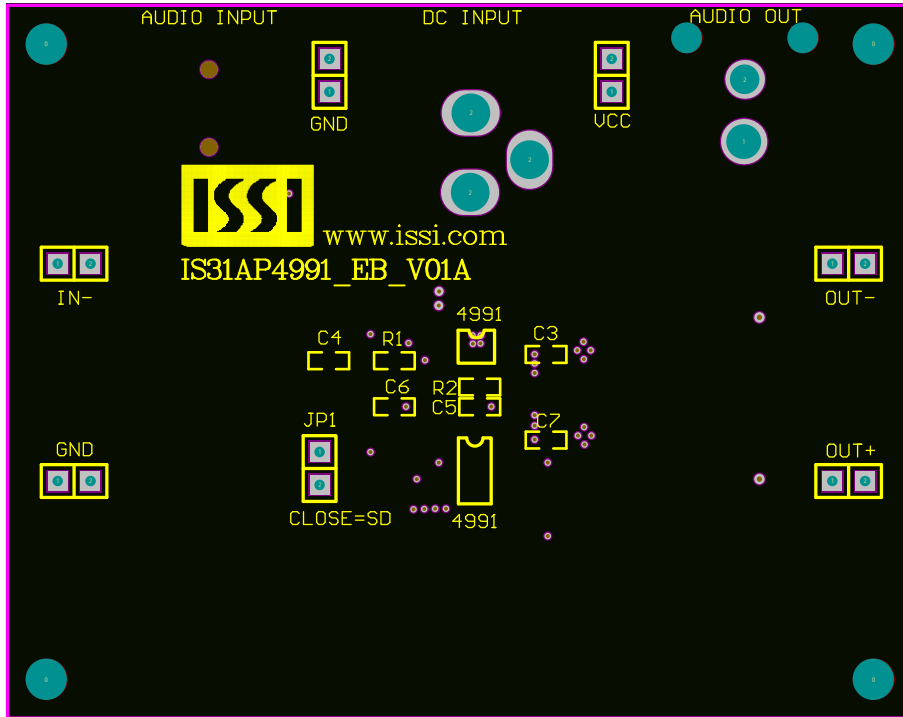

Figure 3. Board Component Placement Guide -Top Layer

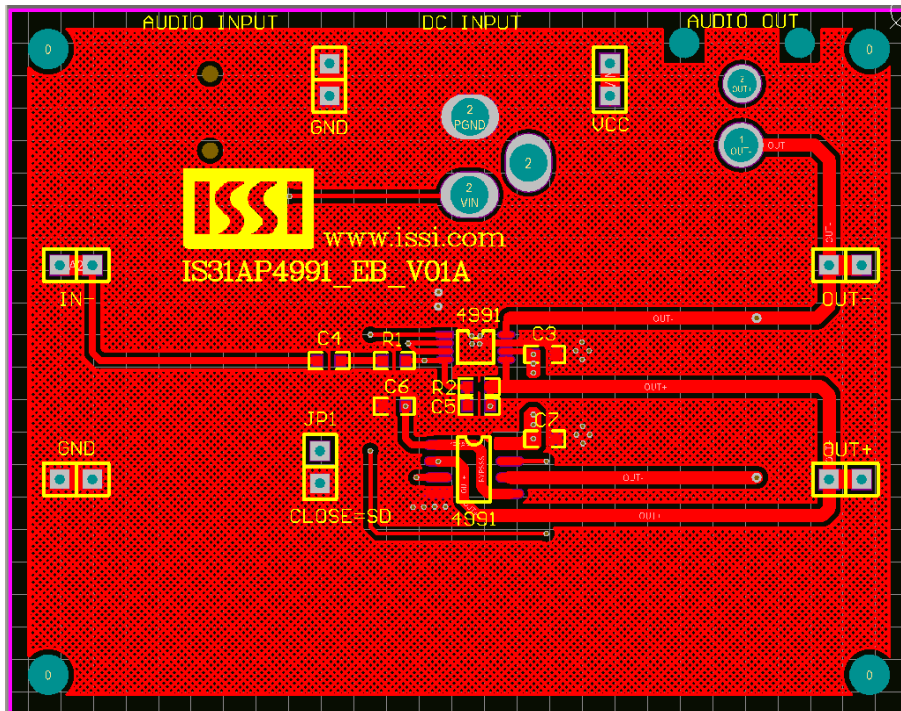

Figure 4. Board PCB Layout- Top Layer

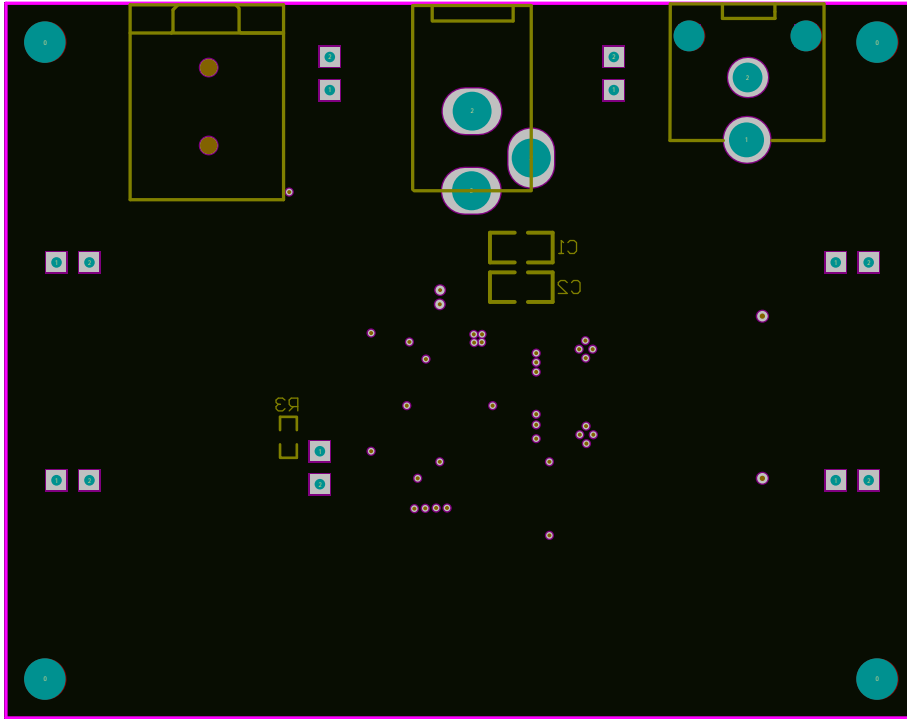

Figure 5. Board Component Placement Guide -Bottom Layer

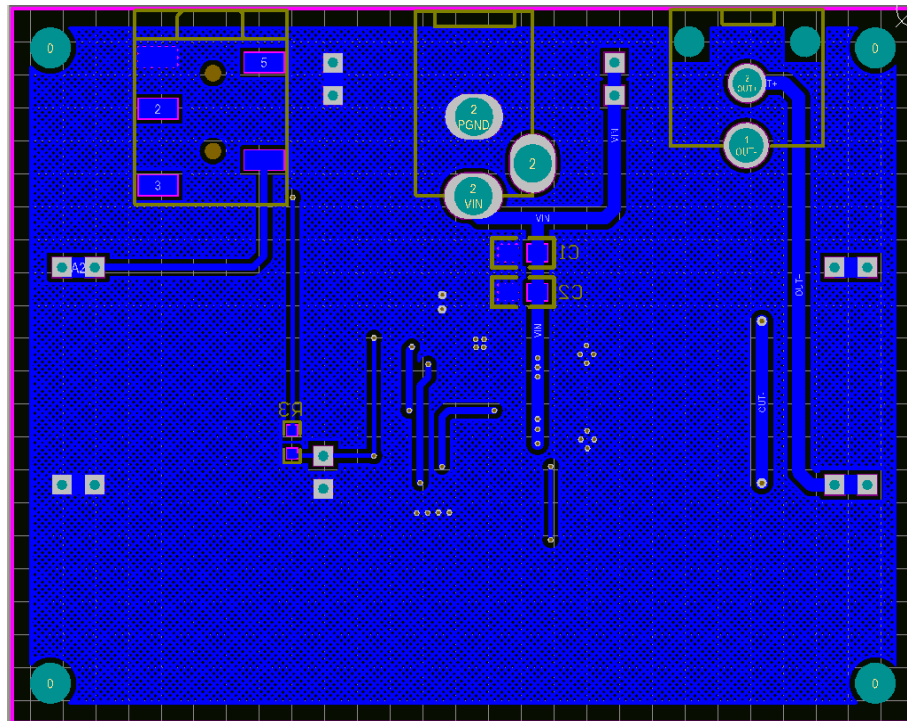

Figure 6. Board PCB Layout -Bottom Layer



Copyright © 2011 Integrated Silicon Solution, Inc. All rights reserved. ISSI reserves the right to make changes to this specification and its products at any time without notice. ISSI assumes no liability arising out of the application or use of any information, products or services described herein. Customers are advised to obtain the latest version of this device specification before relying on any published information and before placing orders for products.

Integrated Silicon Solution, Inc. does not recommend the use of any of its products in life support applications where the failure or malfunction of the product can reasonably be expected to cause failure of the life support system or to significantly affect its safety or effectiveness. Products are not authorized for use in such applications unless Integrated Silicon Solution, Inc. receives written assurance to its satisfaction, that:

- a.) the risk of injury or damage has been minimized;
- b.) the user assume all such risks; and
- c.) potential liability of Integrated Silicon Solution, Inc is adequately protected under the circumstances